

***MTA1 CAN, M1 10Prog CAN, AT1 CAN,
AT1 CoarseFine CAN, M1, AT1, AT1
CourseFine, RA 12, RA 23, RA T1, FS
002 CAN, FS 002***



Návod k používání

1 ÚVOD	3
1.1 Vybavení	3
2 OBSLUHA	3
2.1 Funkce	3
3 OBJEDNÁVÁNÍ NÁHRADNÍCH DÍLŮ	5
ROZMĚROVÝ VÝKRES	6
SCHEMA	8
OBJEDNACÍ ČÍSLO	13
SPOTŘEBNÍ DÍLY	14

1 ÚVOD

Tyto dálkové ovladače mohou ovládat proud, rychlost podávání drátu, napětí nebo volbu programu.

Příslušenství k výrobku ESAB lze nalézt na straně 14.

1.1 Vybavení

Dálkové ovladače se dodávají s návodem k obsluze.



FS 002 CAN a FS 002 se dodávají s 5m propojovacím kabelem, propojovací kabel pro jiné dálkové ovladače lze objednat samostatně.



2 OBSLUHA

Zapojte dálkový ovladač do zásuvky pro dálkové ovládání na napájecím zdroji nebo podavači.

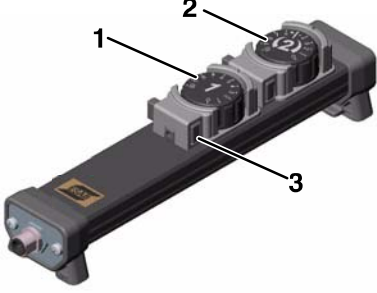
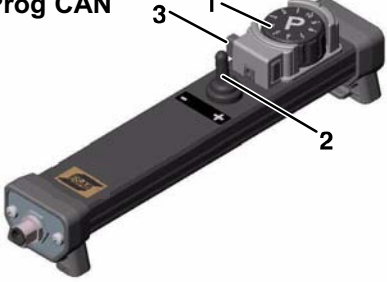
Při zapojování dálkového ovladače ve stroji Aristo vyrobeném před rokem 2005 se musí v některých případech aktualizovat software ovládacího panelu, aby dálkový ovladač fungoval správně.

2.1 Funkce

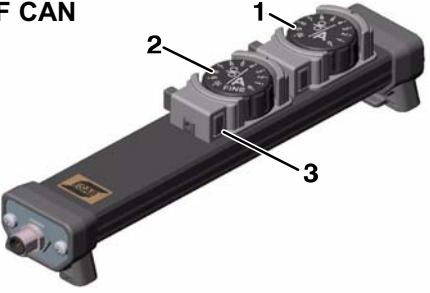
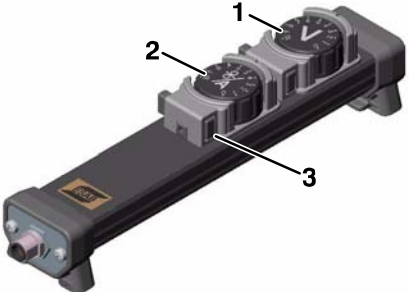
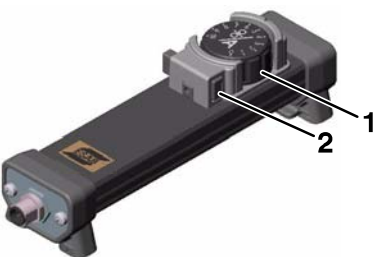
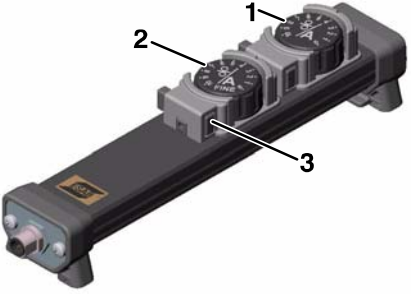
<p>MTA1 CAN</p> 	<p>Dálkové ovládání CAN pro svařování MIG/MAG, TIG a MMA.</p> <p>1 MIG/MAG: Nastavení rychlosti podávání drátu TIG: Nastavení proudu Impulsní TIG: Nastavení impulsního proudu MMA: Nastavení proudu</p> <p>2 MIG/MAG: Nastavení napětí nebo odchylky napětí +/- od synergické křivky TIG: Žádná funkce Impulsní TIG: Nastavení proudu pozadí MMA: Nastavení síly oblouku</p> <p>3 Pojistné kolečko</p>
<p>M1 10Prog CAN</p> 	<p>Dálkové ovládání CAN pro svařování MIG/MAG, TIG a MMA.</p> <p>1 Volba jednoho z deseti programů</p> <p>2 MIG/MAG: Odchylka napětí +/- od zvoleného programu TIG a MMA: Nastavení svařovacího proudu +/- od zvoleného programu Impulsní TIG: Nastavení impulsního proudu +/- od zvoleného programu</p> <p>3 Pojistné kolečko</p>
<p>AT1 CAN</p> 	<p>Dálkové ovládání CAN pro svařování MMA a TIG.</p> <p>1 Nastavení proudu</p> <p>2 Pojistné kolečko</p>

<p>AT1 CF CAN</p> 	<p>Dálkové ovládání CAN pro svařování MMA a TIG.</p> <p>1 2 Hrubé nastavení proudu 3 Jemné nastavení proudu Pojistné kolečko</p>
<p>M1</p> 	<p>Dálkové ovládání pro svařování MIG/MAG</p> <p>1 Nastavení napětí 2 Nastavení rychlosti podávání drátu 3 Pojistné kolečko</p>
<p>AT1</p> 	<p>Dálkové ovládání pro svařování MMA a TIG</p> <p>1 Nastavení proudu 2 Pojistné kolečko</p>
<p>AT1 CF</p> 	<p>Dálkové ovládání pro svařování MMA a TIG</p> <p>1 Hrubé nastavení proudu 2 Jemné nastavení proudu 3 Pojistné kolečko</p>
<p>RA 12</p> 	<p>Adaptér dálkového ovládání CAN. Používá se k připojení MMA1, MMA2 dálkových ovladačů k zařízení CAN.</p> <p>1 12-kolíkový konektor</p>
<p>RA 23</p> 	<p>Adaptér dálkového ovládání CAN. Používá se k připojení svařovací pistole s voličem programů RS3, MIG2 (2 Knoflík) k zařízení CAN.</p> <p>1 23-kolíkový konektor</p>

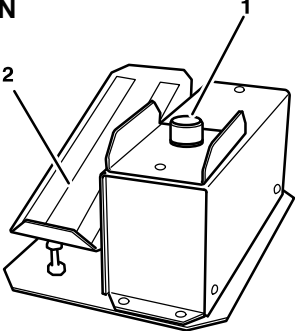
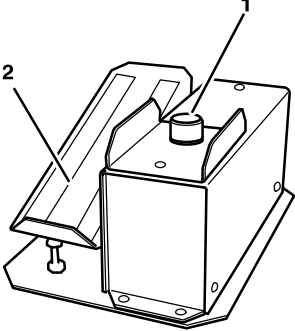
<p>RA T1</p> 	<p>Adaptér standardu CAN, používaný ke spojení hořáků TIG s funkcí +/- pro zařízení standardu CAN.</p> <p>POZOR! Dodává se s držákem a 0,25m kabelem.</p>
<p>FS 002 CAN</p> 	<p>Dálkové ovládání CAN pro svařování TIG.</p> <p>1 Potenciometr na nastavování svařovacího proudu, polohy 1 - 10.</p> <p>2 Nožní pedál na spouštění svařování a nastavování svařovacího proudu.</p> <p>Pokud je potenciometr nastaven na polohu 10, proud se nastavuje od minima do maxima nožním pedálem.</p> <p>Pokud je potenciometr nastaven na polohu 5, proud se nastavuje od minima do 50 % maxima nožním pedálem.</p>
<p>FS 002</p> 	<p>Dálkové ovládání pro svařování TIG.</p> <p>1 Potenciometr na nastavování svařovacího proudu, polohy 1 - 10.</p> <p>2 Nožní pedál na spouštění svařování a nastavování svařovacího proudu.</p> <p>Pokud je potenciometr nastaven na polohu 10, proud se nastavuje od minima do maxima nožním pedálem.</p> <p>Pokud je potenciometr nastaven na polohu 5, proud se nastavuje od minima do 50 % maxima nožním pedálem.</p>

3 OBJEDNÁVÁNÍ NÁHRADNÍCH DÍLŮ



UPOZORNĚNÍ!

Závazky ze záruky dodavatele ztrácejí platnost, jestliže se zákazník během záruční doby pokusí libovolným způsobem zasahovat do výrobku za účelem odstranění jakékoliv závady.

Náhradní díly si můžete objednat u nejbližšího prodejce společnosti ESAB; viz poslední stránku této publikace.

Rozměrový výkres

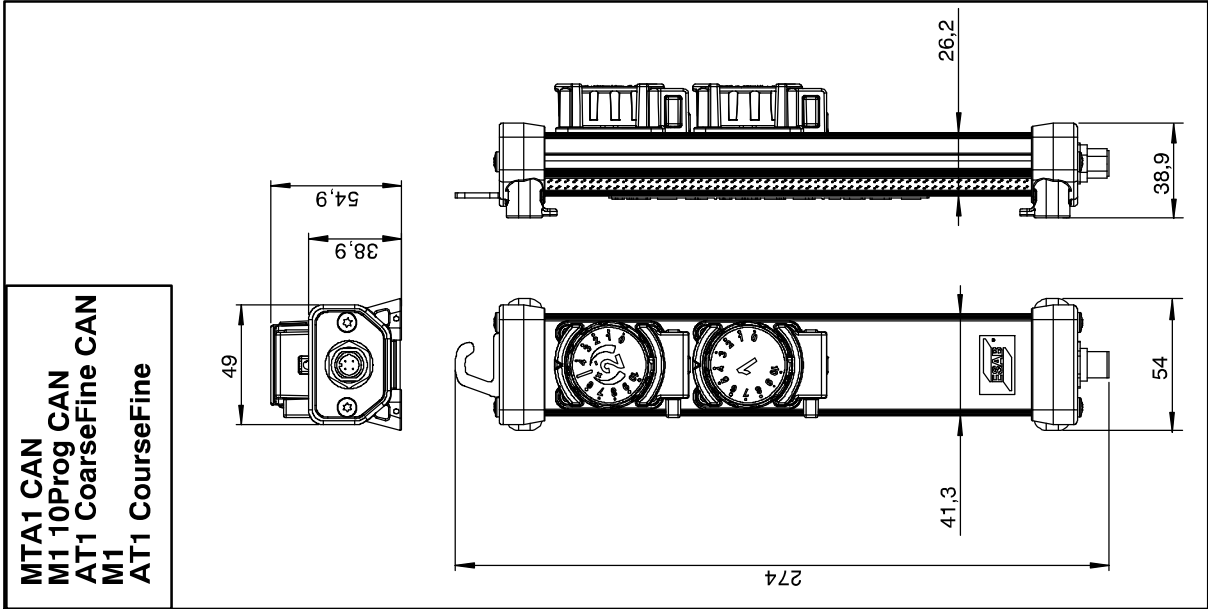
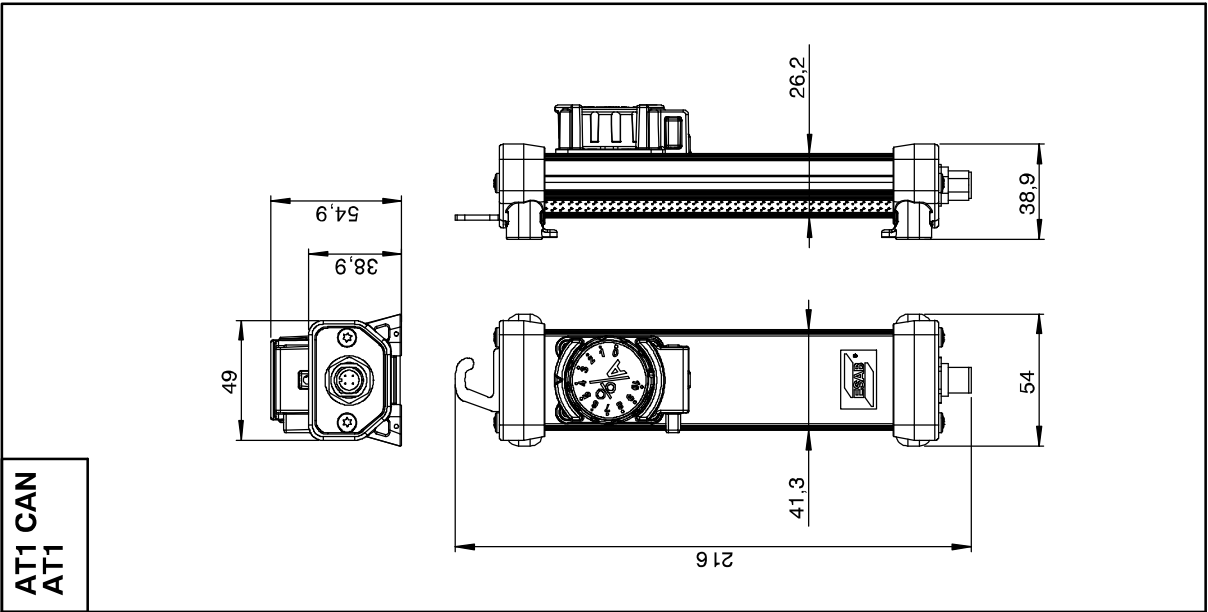
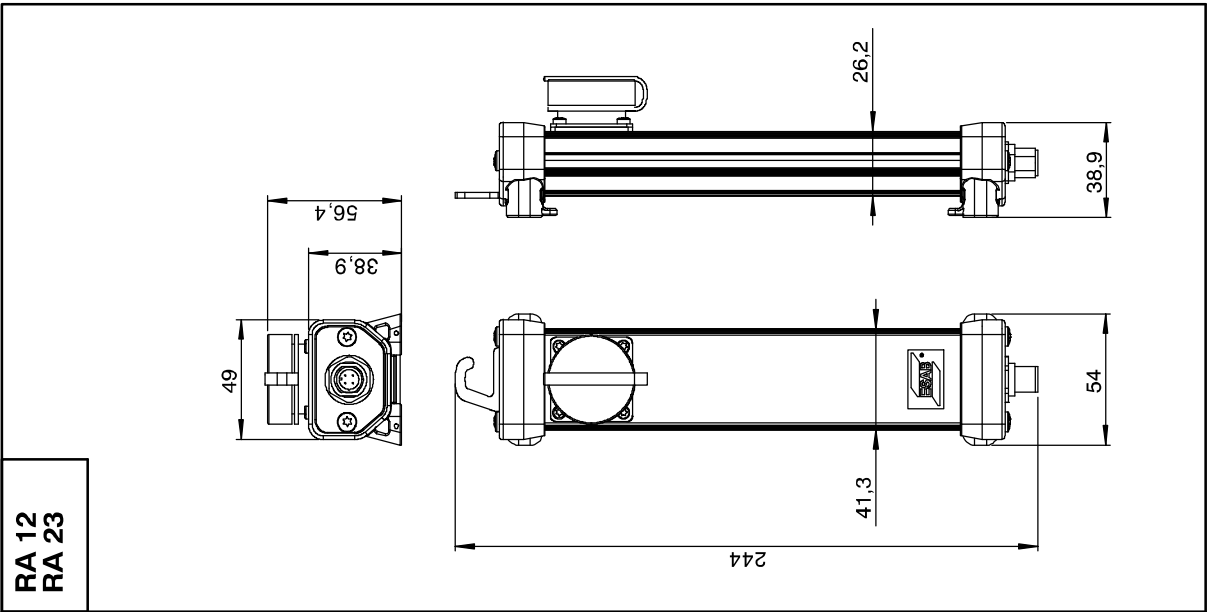

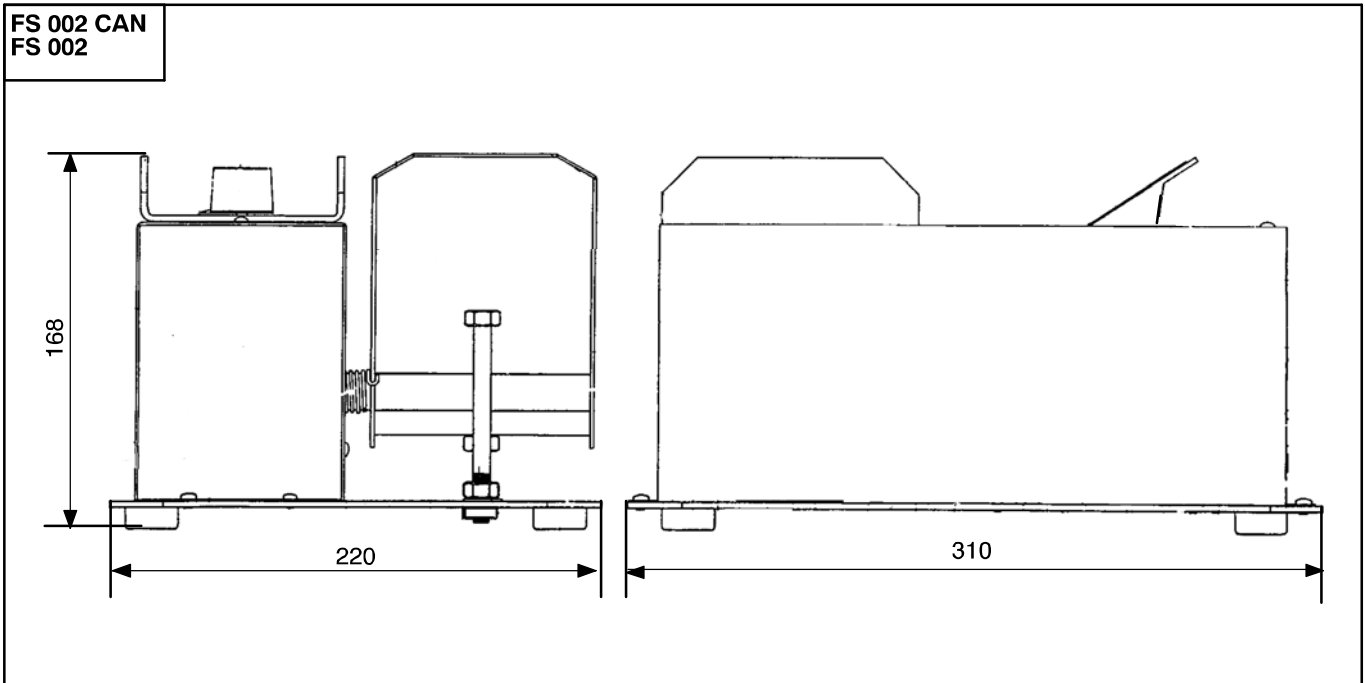
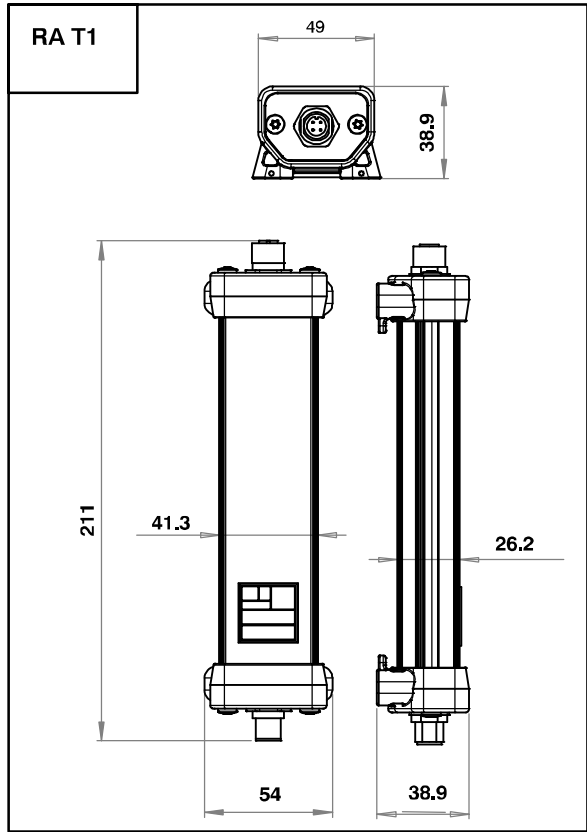

Schema

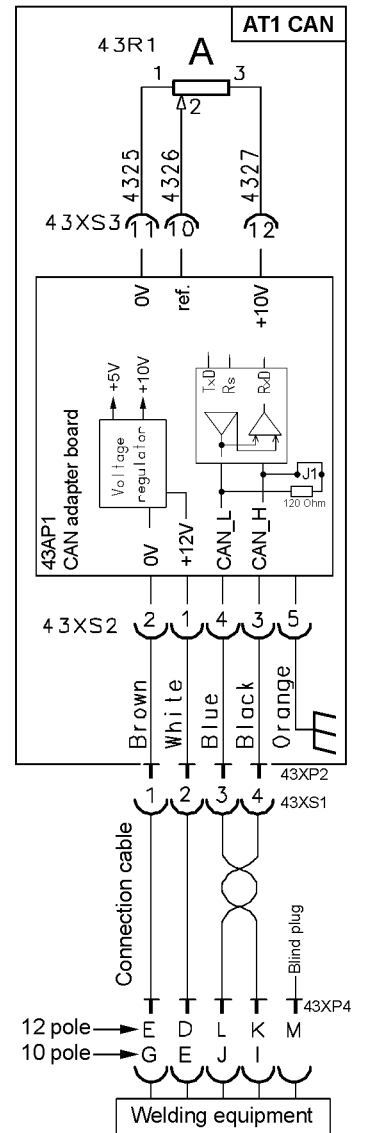
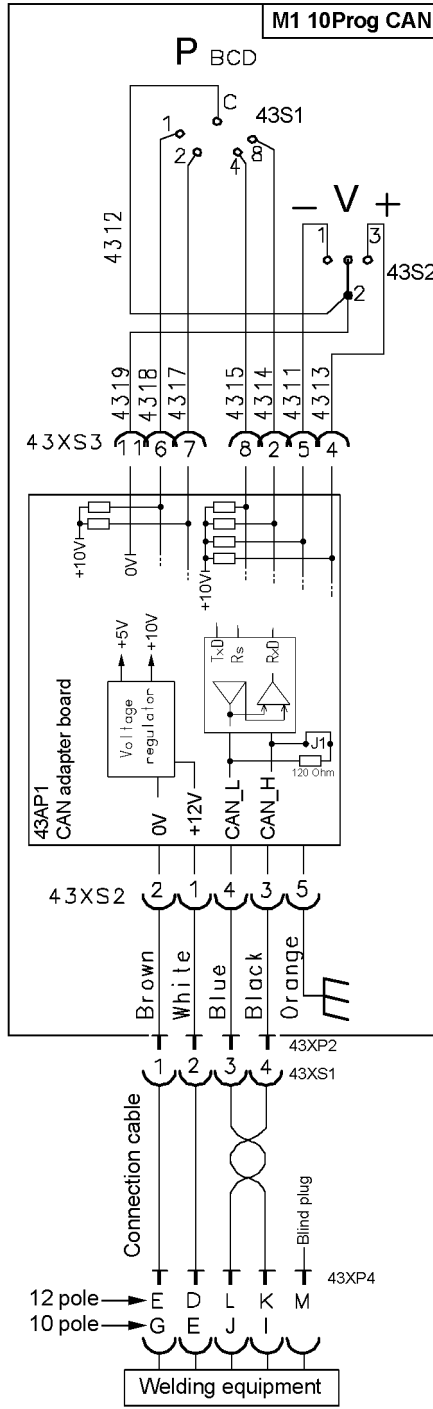
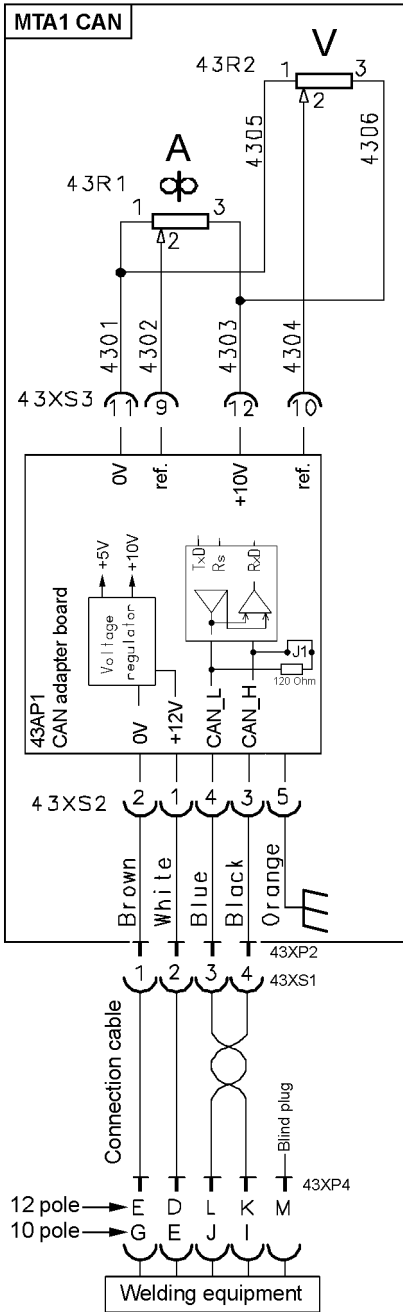

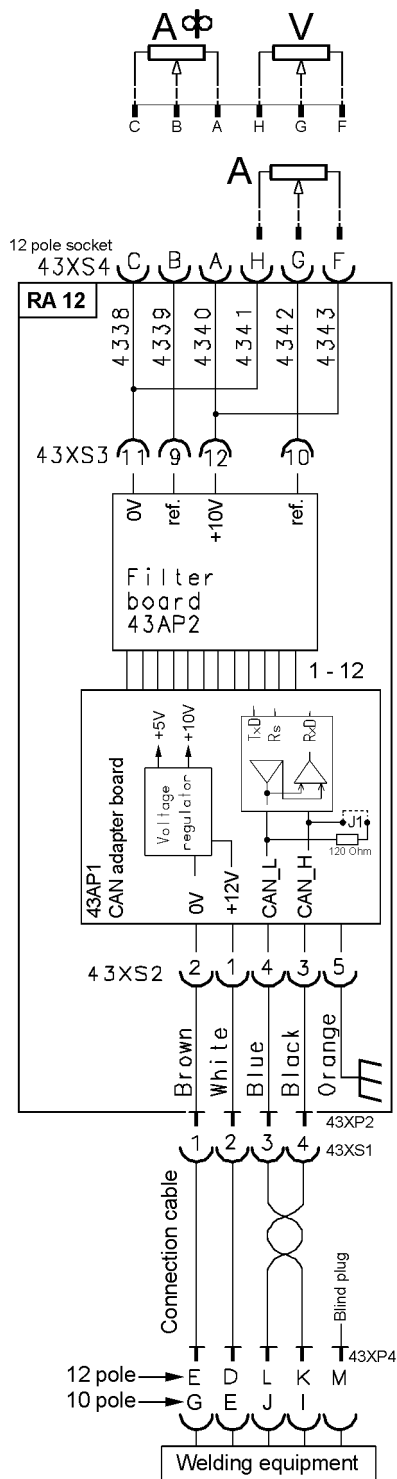

RA12 up to and including serial number
506-640-4574

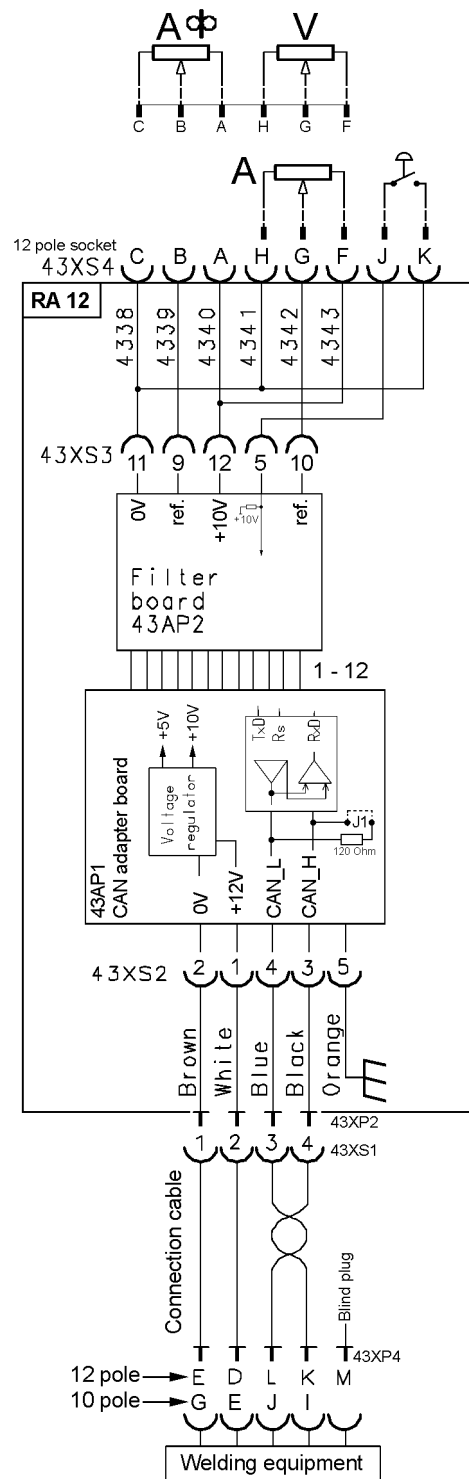

RA 12 from serial number 506-640-4575

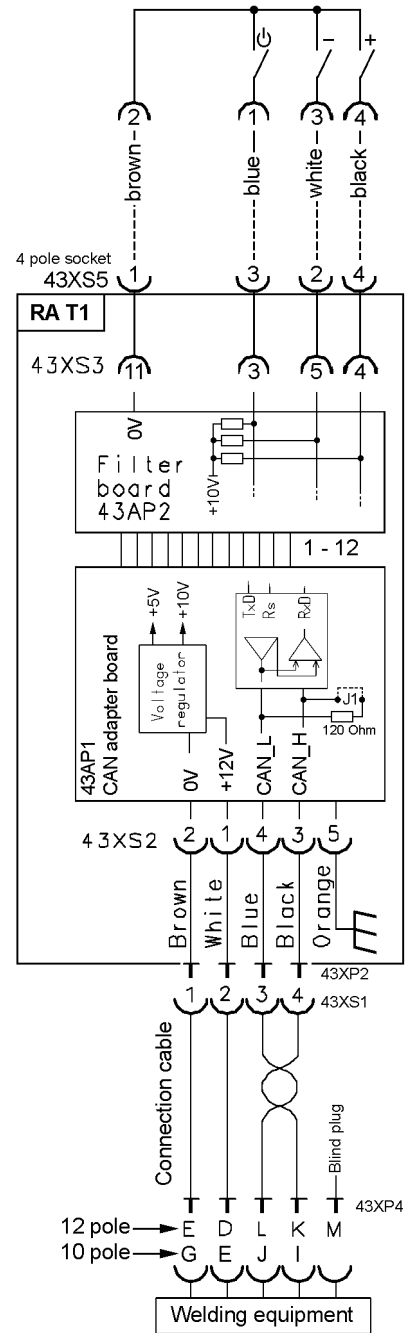
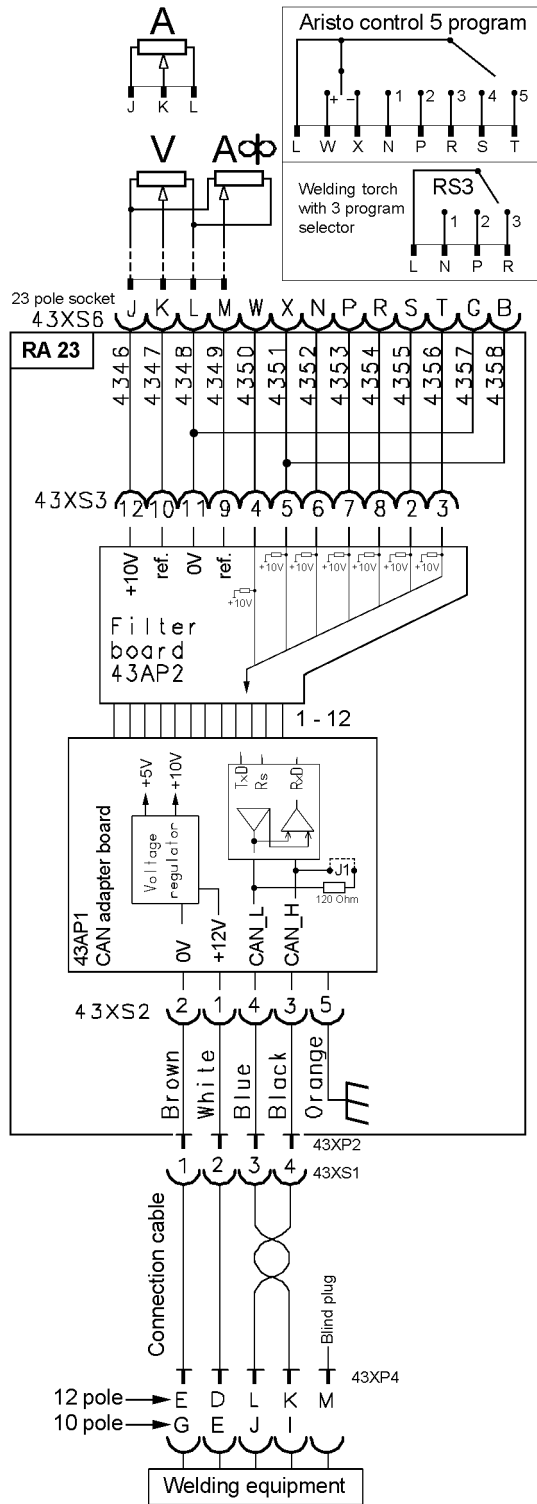

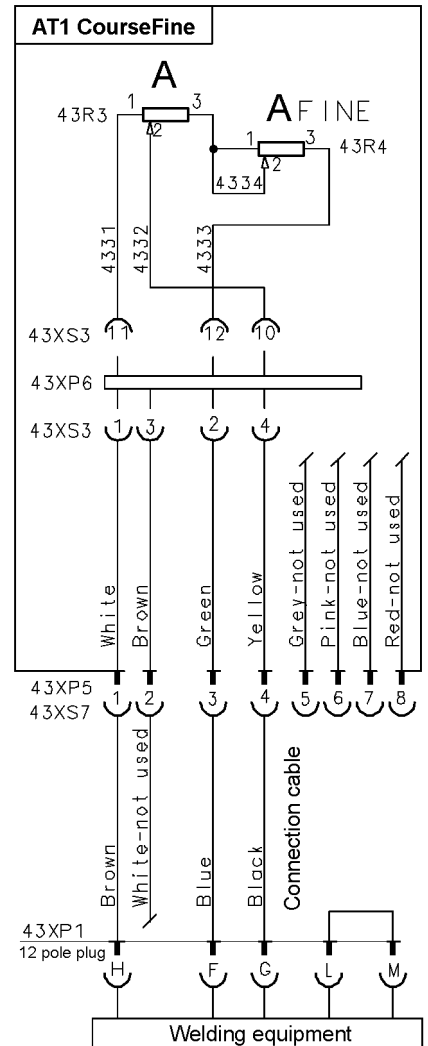
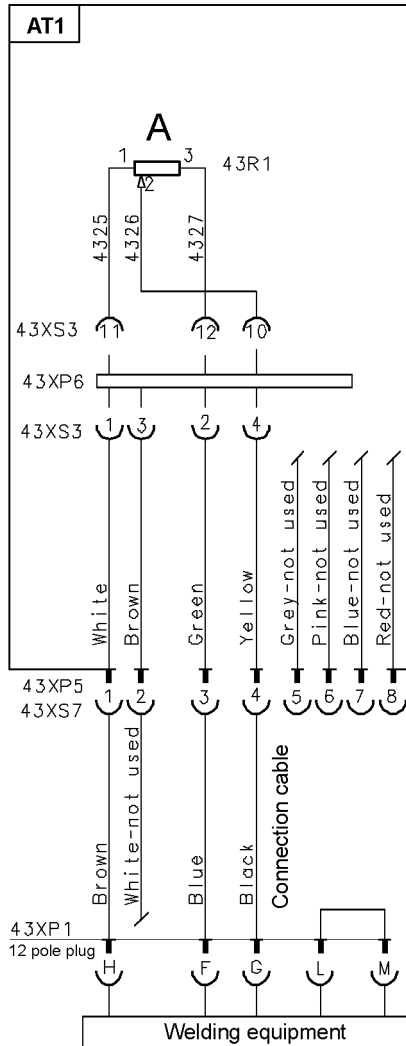
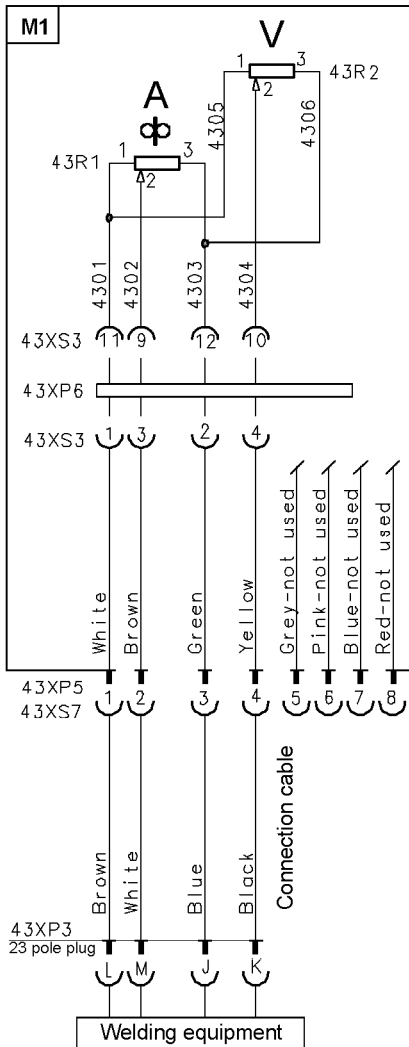

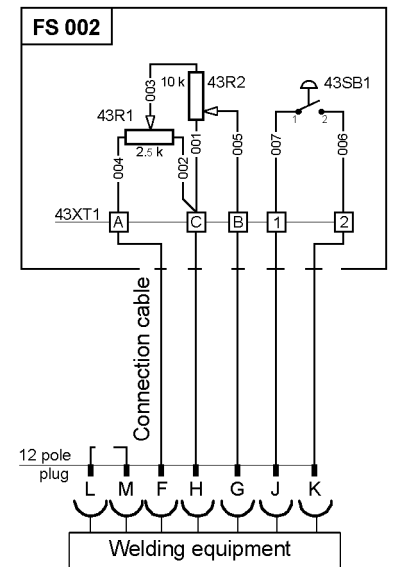
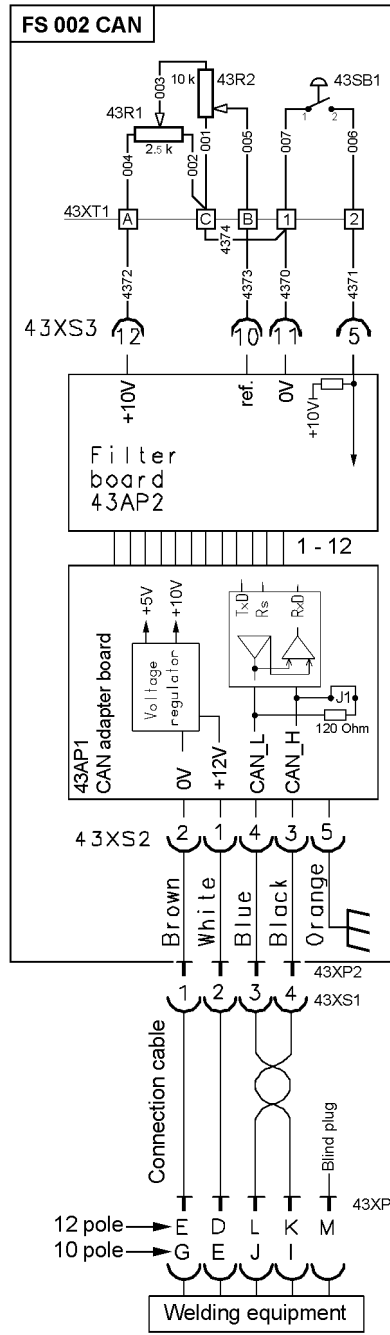
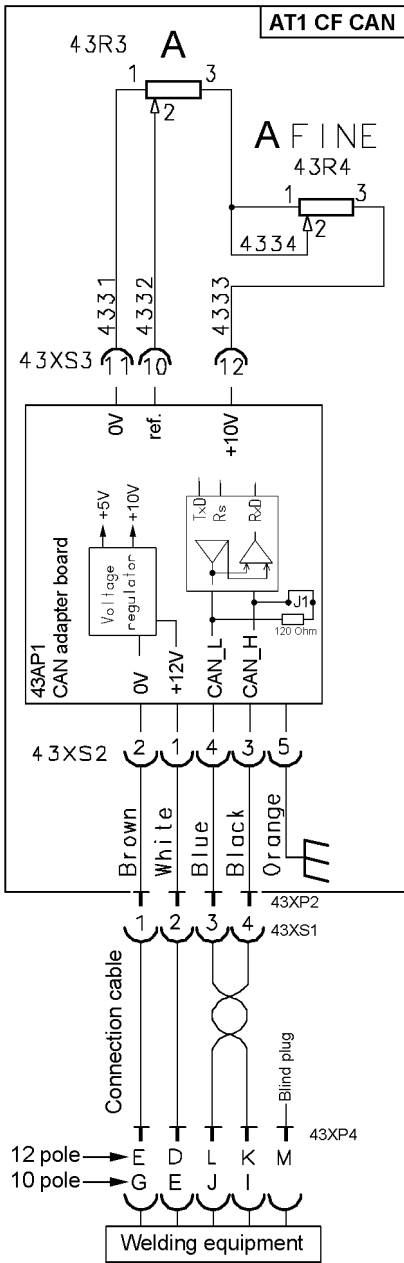

Objednací číslo

Remote control	Ordering no.	Remote control	Ordering no.
MTA1 CAN 	0459 491 880	M1 	0459 491 895
M1 10Prog CAN 	0459 491 882	AT1 	0459 491 896
AT1 CAN 	0459 491 883	AT1 CoarseFine 	0459 491 897
AT1 CoarseFine CAN 	0459 491 884	RA 12 	0459 491 910
FS 002 CAN 	0349 090 890	RA 23 	0459 491 911
FS 002 	0349 090 886	RA T1 12 pole 	0459 491 912
		RA T1 10 pole 	0459 491 913

Spare parts list 0459 576 990

The spare parts list is available on the Internet at www.esab.com

MTA1 CAN, M1 10P CAN, AT1 CAN, AT1 CF CAN, RA 12, RA 23, RA T1, M1, AT1, AT1 CF, FS 002 CAN, FS 002

Spotřební díly

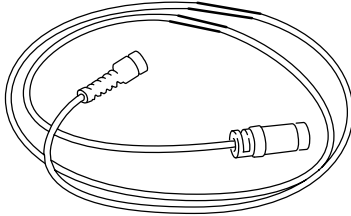
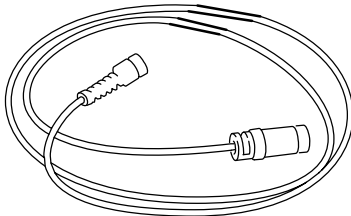
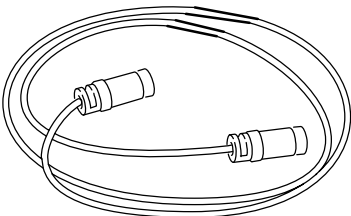
	<p>Remote cable CAN 4 pole - 12 pole</p> <table border="0"> <tr><td>0.25 m</td><td>0459 554 884</td></tr> <tr><td>5 m</td><td>0459 554 880</td></tr> <tr><td>10 m</td><td>0459 554 881</td></tr> <tr><td>15 m</td><td>0459 554 882</td></tr> <tr><td>25 m</td><td>0459 554 883</td></tr> <tr><td>5 m Heavy Duty</td><td>0459 554 980</td></tr> <tr><td>10 m Heavy Duty</td><td>0459 554 981</td></tr> </table> <p>Remote cable CAN 4 pole - 10 pole</p> <table border="0"> <tr><td>0.25 m</td><td>0459 960 883</td></tr> <tr><td>5 m</td><td>0459 960 880</td></tr> <tr><td>10 m</td><td>0459 960 881</td></tr> <tr><td>25 m</td><td>0459 960 882</td></tr> <tr><td>5 m Heavy Duty</td><td>0459 960 980</td></tr> <tr><td>10 m Heavy Duty</td><td>0459 960 981</td></tr> <tr><td>25 m Heavy Duty</td><td>0459 960 982</td></tr> </table>	0.25 m	0459 554 884	5 m	0459 554 880	10 m	0459 554 881	15 m	0459 554 882	25 m	0459 554 883	5 m Heavy Duty	0459 554 980	10 m Heavy Duty	0459 554 981	0.25 m	0459 960 883	5 m	0459 960 880	10 m	0459 960 881	25 m	0459 960 882	5 m Heavy Duty	0459 960 980	10 m Heavy Duty	0459 960 981	25 m Heavy Duty	0459 960 982
0.25 m	0459 554 884																												
5 m	0459 554 880																												
10 m	0459 554 881																												
15 m	0459 554 882																												
25 m	0459 554 883																												
5 m Heavy Duty	0459 554 980																												
10 m Heavy Duty	0459 554 981																												
0.25 m	0459 960 883																												
5 m	0459 960 880																												
10 m	0459 960 881																												
25 m	0459 960 882																												
5 m Heavy Duty	0459 960 980																												
10 m Heavy Duty	0459 960 981																												
25 m Heavy Duty	0459 960 982																												
	<p>Remote cable 8 pole - 12 pole for remote controls AT1 and AT1 CF</p> <table border="0"> <tr><td>5 m</td><td>0459 552 880</td></tr> <tr><td>10 m</td><td>0459 552 881</td></tr> <tr><td>15 m</td><td>0459 552 882</td></tr> <tr><td>25 m</td><td>0459 552 883</td></tr> </table> <p>Remote cable 8 pole - 23 pole for remote control M1</p> <table border="0"> <tr><td>5 m</td><td>0459 553 880</td></tr> </table>	5 m	0459 552 880	10 m	0459 552 881	15 m	0459 552 882	25 m	0459 552 883	5 m	0459 553 880																		
5 m	0459 552 880																												
10 m	0459 552 881																												
15 m	0459 552 882																												
25 m	0459 552 883																												
5 m	0459 553 880																												
	<p>Extension cable 12 pole for remote controls AT1, AT1 CF and FS 002</p> <table border="0"> <tr><td>25 m</td><td>0367 662 880</td></tr> </table>	25 m	0367 662 880																										
25 m	0367 662 880																												

ESAB subsidiaries and representative offices

Europe AUSTRIA ESAB Ges.m.b.H Vienna-Liesing Tel: +43 1 888 25 11 Fax: +43 1 888 25 11 85 BELGIUM S.A. ESAB N.V. Brussels Tel: +32 2 745 11 00 Fax: +32 2 745 11 28 BULGARIA ESAB Kft Representative Office Sofia Tel/Fax: +359 2 974 42 88 THE CZECH REPUBLIC ESAB VAMBERK s.r.o. Vamberk Tel: +420 2 819 40 885 Fax: +420 2 819 40 120 DENMARK Aktieselskabet ESAB Herlev Tel: +45 36 30 01 11 Fax: +45 36 30 40 03 FINLAND ESAB Oy Helsinki Tel: +358 9 547 761 Fax: +358 9 547 77 71 FRANCE ESAB France S.A. Cergy Pontoise Tel: +33 1 30 75 55 00 Fax: +33 1 30 75 55 24 GERMANY ESAB GmbH Solingen Tel: +49 212 298 0 Fax: +49 212 298 218 GREAT BRITAIN ESAB Group (UK) Ltd Waltham Cross Tel: +44 1992 76 85 15 Fax: +44 1992 71 58 03 ESAB Automation Ltd Andover Tel: +44 1264 33 22 33 Fax: +44 1264 33 20 74 HUNGARY ESAB Kft Budapest Tel: +36 1 20 44 182 Fax: +36 1 20 44 186 ITALY ESAB Saldatura S.p.A. Bareggio (Mi) Tel: +39 02 97 96 8.1 Fax: +39 02 97 96 87 01 THE NETHERLANDS ESAB Nederland B.V. Amersfoort Tel: +31 33 422 35 55 Fax: +31 33 422 35 44	NORWAY AS ESAB Larvik Tel: +47 33 12 10 00 Fax: +47 33 11 52 03 POLAND ESAB Sp.zo.o. Katowice Tel: +48 32 351 11 00 Fax: +48 32 351 11 20 PORTUGAL ESAB Lda Lisbon Tel: +351 8 310 960 Fax: +351 1 859 1277 ROMANIA ESAB Romania Trading SRL Bucharest Tel: +40 316 900 600 Fax: +40 316 900 601 RUSSIA LLC ESAB Moscow Tel: +7 (495) 663 20 08 Fax: +7 (495) 663 20 09 SLOVAKIA ESAB Slovakia s.r.o. Bratislava Tel: +421 7 44 88 24 26 Fax: +421 7 44 88 87 41 SPAIN ESAB Ibérica S.A. Alcalá de Henares (MADRID) Tel: +34 91 878 3600 Fax: +34 91 802 3461 SWEDEN ESAB Sverige AB Gothenburg Tel: +46 31 50 95 00 Fax: +46 31 50 92 22 ESAB international AB Gothenburg Tel: +46 31 50 90 00 Fax: +46 31 50 93 60 SWITZERLAND ESAB AG Dietikon Tel: +41 1 741 25 25 Fax: +41 1 740 30 55 UKRAINE ESAB Ukraine LLC Kiev Tel: +38 (044) 501 23 24 Fax: +38 (044) 575 21 88	North and South America ARGENTINA CONARCO Buenos Aires Tel: +54 11 4 753 4039 Fax: +54 11 4 753 6313 BRAZIL ESAB S.A. Contagem-MG Tel: +55 31 2191 4333 Fax: +55 31 2191 4440 CANADA ESAB Group Canada Inc. Mississauga, Ontario Tel: +1 905 670 02 20 Fax: +1 905 670 48 79 MEXICO ESAB Mexico S.A. Monterrey Tel: +52 8 350 5959 Fax: +52 8 350 7554 USA ESAB Welding & Cutting Products Florence, SC Tel: +1 843 669 44 11 Fax: +1 843 664 57 48 Asia/Pacific CHINA Shanghai ESAB A/P Shanghai Tel: +86 21 2326 3000 Fax: +86 21 6566 6622 INDIA ESAB India Ltd Calcutta Tel: +91 33 478 45 17 Fax: +91 33 468 18 80 INDONESIA P.T. ESABindo Pratama Jakarta Tel: +62 21 460 0188 Fax: +62 21 461 2929 JAPAN ESAB Japan Tokyo Tel: +81 45 670 7073 Fax: +81 45 670 7001 MALAYSIA ESAB (Malaysia) Snd Bhd USJ Tel: +603 8023 7835 Fax: +603 8023 0225 SINGAPORE ESAB Asia/Pacific Pte Ltd Singapore Tel: +65 6861 43 22 Fax: +65 6861 31 95	SOUTH KOREA ESAB SeAH Corporation Kyungnam Tel: +82 55 269 8170 Fax: +82 55 289 8864 UNITED ARAB EMIRATES ESAB Middle East FZE Dubai Tel: +971 4 887 21 11 Fax: +971 4 887 22 63 Africa EGYPT ESAB Egypt Dokki-Cairo Tel: +20 2 390 96 69 Fax: +20 2 393 32 13 SOUTH AFRICA ESAB Africa Welding & Cutting Ltd Durbanvill 7570 - Cape Town Tel: +27 (0)21 975 8924 Distributors <i>For addresses and phone numbers to our distributors in other countries, please visit our home page</i> www.esab.com
---	--	--	---



ESAB AB
SE-695 81 LAXA
SWEDEN
Phone +46 584 81 000

www.esab.com

